

WHEELACT CLASSIC / AXLEACT CLASSIC

Light Weight Caliper with SafePark®

The newly designed conventional brake caliper unit **WheelAct Classic / AxleAct Classic** combines the benefits of the SafePark® parking brake cylinder with lightweight design. The result is a brake caliper unit with improved functionality and significantly reduced weight and installation space, but with identical interfaces to the bogie and service-proven robust design principles (e.g. suspension, bushing design, etc.).



Key features

- Light caliper design
- SafePark® cylinder
- Two-piece pull rod
- Robust locking mechanism



Advantages

- Less installation space in the bogie
- No superposition of service and parking brake
- SafePark® suitable for all brake caliper units
- Reduction of weight, especially together with new light weight caliper design:
 - Service brake from 73 kg to 53 kg
 - Parking brake from 95 kg to 60 kg



KNORR-BREMSE



Design Features

Light Weight Caliper

- Weight reduction

Locking mechanism

- Poka-yoke robustness
- Stone blasting protection

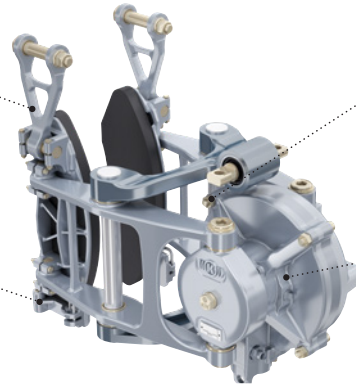

Two-piece pull rod

- Weight reduction
- Simplified production

SafePark® cylinder

- No superposition
- Weight and space reduction
- Less vibration loads

Life-Cycle Assessment – focus Product Carbon Footprint

Light Weight Caliper saves 24% CO₂ emissions during its lifetime

compared to the standard conventional caliper

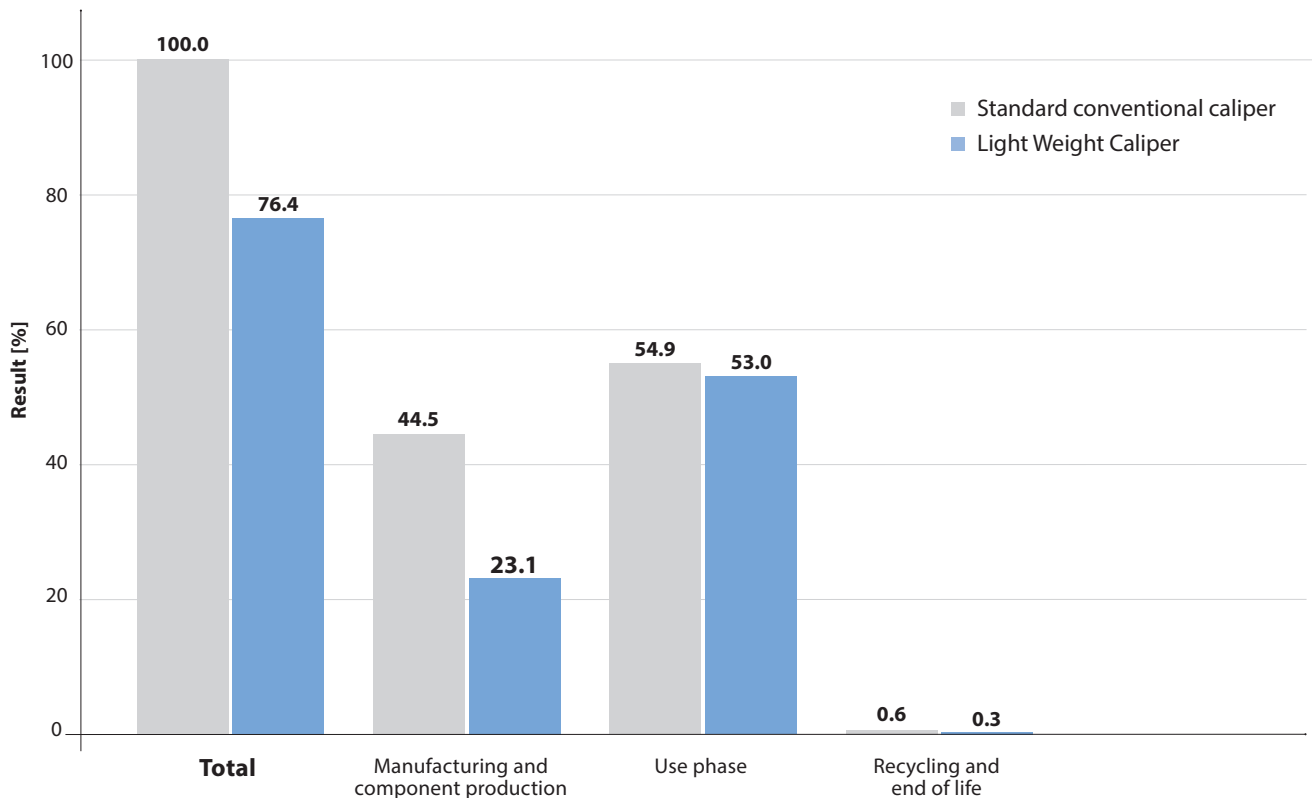

■ Use phase only contains raw material consumption within overhaul period

■ Weight reduction of 33% provides further energy and CO₂-savings in the use phase of a train, i. e. 10 MWh per brake caliper during the lifetime of a typical metro application

Knorr-Bremse Systeme für Schienenfahrzeuge GmbH

Moosacher Straße 80
 80809 Munich
 Germany
 Phone: +49 89 3547-0
 Fax: +49 89 3547-2767
 rail.knorr-bremse.com



KNORR-BREMSE

NEW YORK AIR BRAKE

IFE

MERAK

MICROELETTRICA

SELECTRON

EVAC

ZELISKO

RAILSERVICES