

SANDGRIP

APPLICATIONS

Light Rail Vehicles



KNORR-BREMSE

Superior acceleration and braking under all conditions

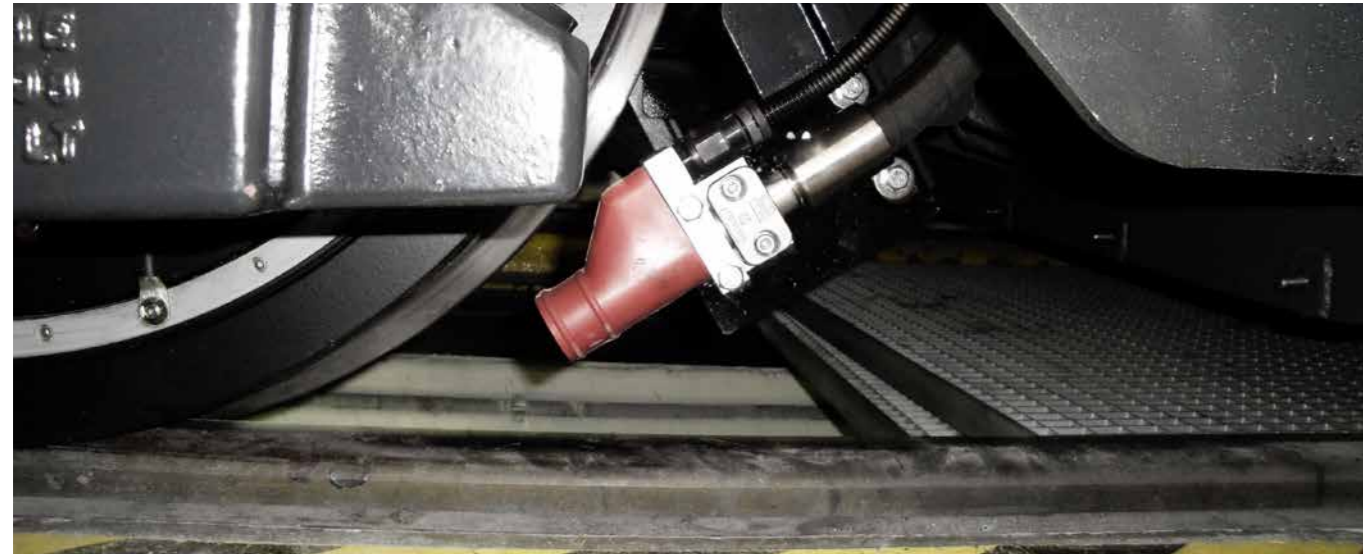

Sanding Systems for LRVs

To safely operate in heavy urban traffic and to master long up-/downhill sections, LRVs and streetcars require an adequate acceleration capability and braking performance. Sanding systems have successfully proven to increase the adhesion between wheel and rail. In combination with a state-of-the-art traction/braking system, sanding systems can reduce braking distances by up to 50% (from initial speed 50 km/h). Additionally our sanding systems offer various possibilities of condition-based maintenance in order to increase the vehicle availability and reduce fault-finding hours and downtimes.

Sand does not behave like a liquid. This characteristic has a tremendous impact on the whole design from sandbox to sand hose as well as the filling situation. Strong expertise is needed to optimize the sanding system for a given installation situation and to ensure a robust and reliable system in the long run. Therefore we offer the entire integration of a sanding system into the vehicle as well as qualified total life cycle support. The broad portfolio of **SandGrip Pneumatic** and **SandGrip Mechanic** sanding units allows customer-specific system configurations for every vehicle project.

All in one location

At its site in Mödling, Austria, Knorr-Bremse has built up decades of experience and know-how in sanding systems for LRVs. The results are thousands of successfully installed systems, which are in operation all over the world. They represent the unique capabilities of Knorr-Bremse from OE system layout definition to modernization of existing systems.

Customer benefits

- Tailor-made system solutions for each and every project
- Comprehensive system integration expertise covering OE design, modernization and retrofit needs
- Optimized total cost of ownership, ready for condition-based maintenance
- Full compliance with railway standards
- Global Knorr-Bremse network for localization, after sales service, etc.
- Extensive range of optional features, e.g. sand flow sensor

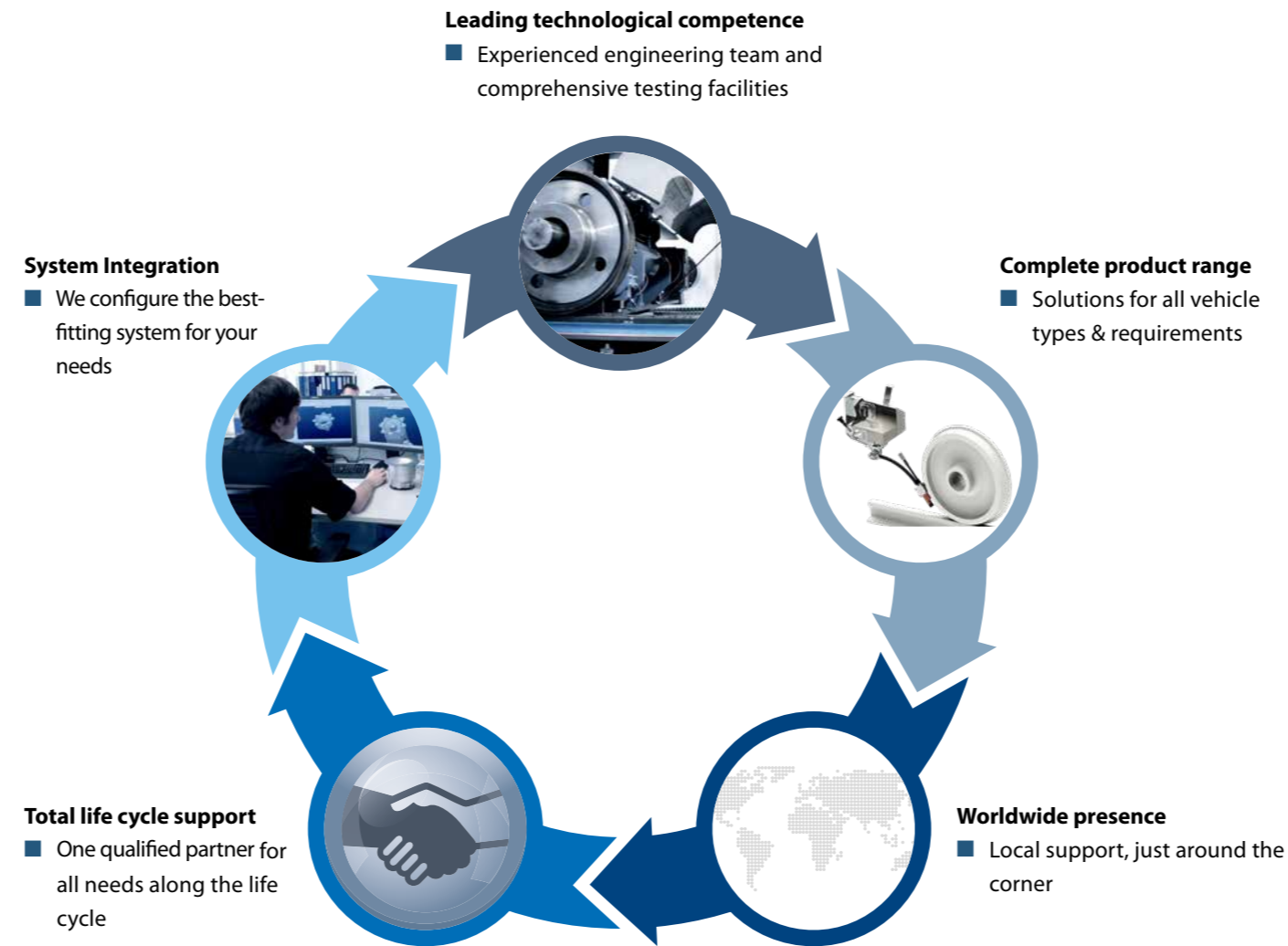

Knorr-Bremse provides support and services over the entire life time of vehicles

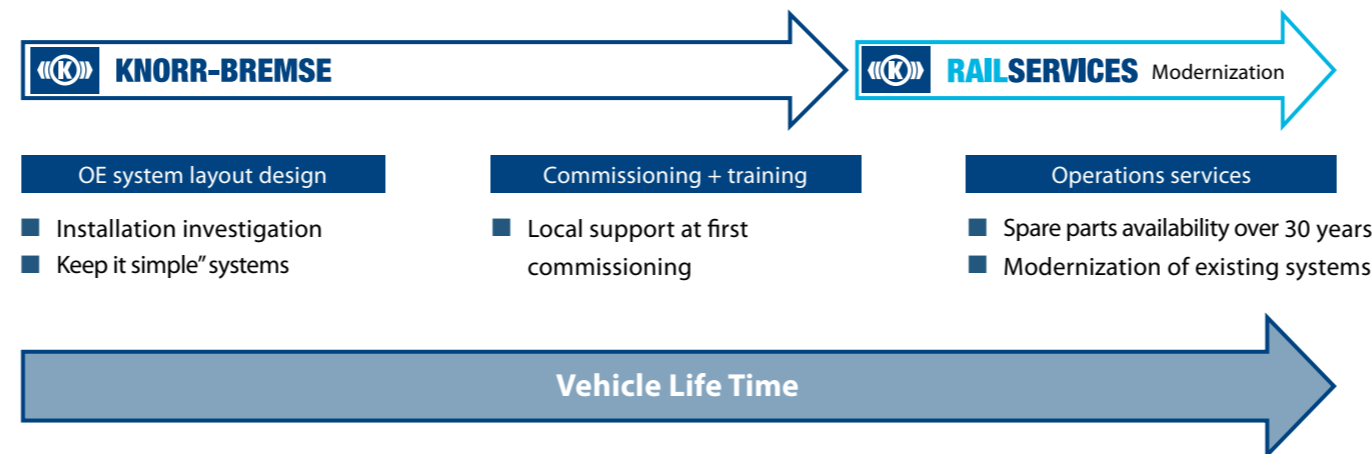

Sanding Units

SandGrip Pneumatic

SandGrip Mechanic



SandGrip Accessories

Sand boxes

Sanding air supply

Sand box accessories

Heaters

Sand sensors and control units





Knorr-Bremse – No.1 in Adhesion Management Best value – Safe – Global

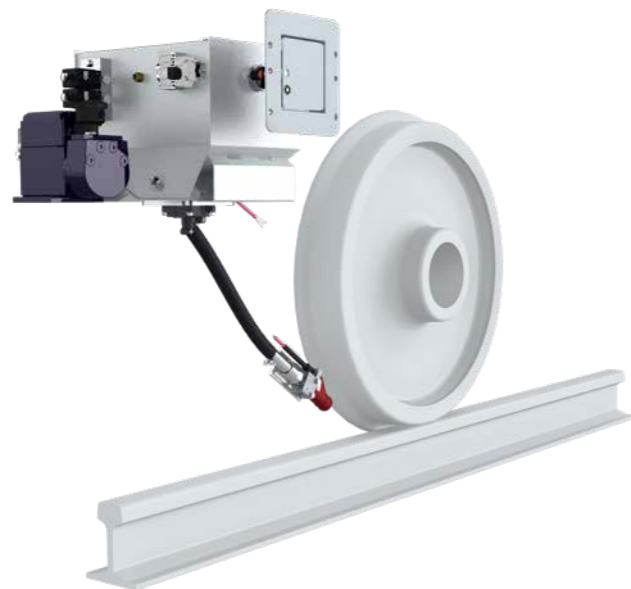

Knorr-Bremse GmbH

Beethovengasse 43-45
2340 Mödling
Austria
Phone: +43 2236 409-0
rail.knorr-bremse.com/de/at

Knorr-Bremse Systeme für Schienenfahrzeuge GmbH

Moosacher Straße 80
80809 Munich
Germany
Phone: +49 89 3547-0
rail.knorr-bremse.com



-  **KNORR-BREMSE**
-  **NEW YORK AIR BRAKE**
-  **IFE**
-  **MERAK**
-  **MICROELETTRICA**
-  **SELECTRON**
-  **EVAC**
-  **ZELSKO**
-  **RAILSERVICES**