

# TREADACT COMPACT

## Tread brake unit

The tread brake unit **TreadAct Compact** is a air-powered brake for rail vehicles comprising brake cylinder, transmission mechanism and automatic slack adjuster. Being compact and space-saving, they can be installed even in bogies with very narrow space restrictions. Depending on the application Knorr-Bremse offers rigid or flexible tread brake units. Both types are highly modularized to match any application, mounting space and operational conditions. This equipment incorporates a proven robust design delivering highest availability and low life-cycle costs.



### Customer benefits

- Compact and modular design
- Preassembled and ready to install
- Constant high efficiency of 95%
- Weight-optimized
- Overhaul period of 8 to 10 years (depending on environmental conditions)
- Low noise because of sealed bearings



### Applications

- Locomotives
- Metros
- Regional & commuter trains
- High-speed trains



**KNORR-BREMSE**

## TreadAct Compact (Type PEC7)

In Rigid Design for Standard Bogies

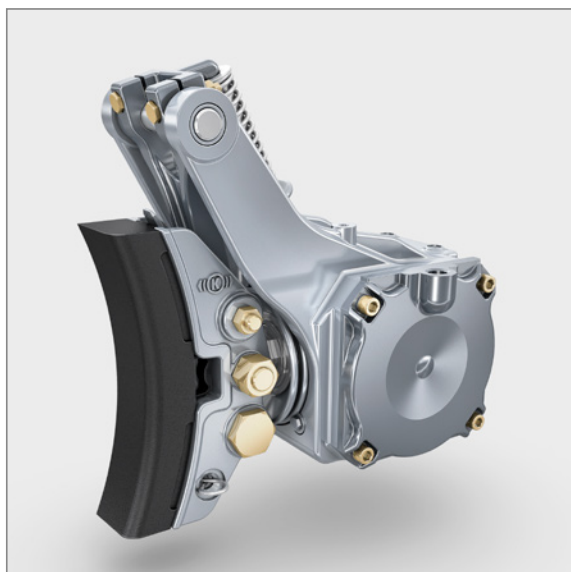

## Key Features

- Standard interface to bogie
- Installation space independent of brake force
- Robust design for very harsh environmental conditions (ice, sand, low temperature -60 °C)
- Sealed bearings for less wear, less noise, low maintenance and longer overhaul intervals
- Superposition of brake forces in failure cases admissible
- Modular design with optional features:
  - spring-operated, pneumatically released parking brake
  - hand-operated parking brake (hand wheel)
  - suitable for UIC, AAR or other brake block types
  - electrical indication of brake status
  - pneumatic valves for various functions

## TreadAct Compact (Type PEC7)

In Flexible Design for High Lateral Axle Movements

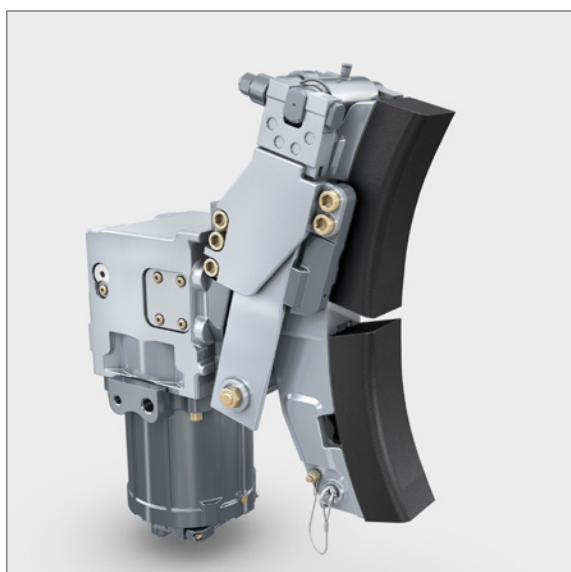

## Technical data

- High variation of internal ratio from 2.0 to 5.5
- Block force of service brake up to 60 kN
- Block force of parking brake up to 45 kN
- Service unit can be added with spring or hand-applied parking brake

### Knorr-Bremse Systeme für Schienenfahrzeuge GmbH

Moosacher Straße 80  
80809 Munich  
Germany  
Phone: +49 89 3547-0  
Fax: +49 89 3547-2767  
rail.knorr-bremse.com



 **KNORR-BREMSE**

 **NEW YORK AIR BRAKE**

 **IFE**

 **MERAK**

 **MICROELETTRICA**

 **SELECTRON**

 **EVAC**

 **ZELISKO**

 **RAILSERVICES**