

PISTONSUPPLY Eco

The Knorr-Bremse oil-free piston compressor has created a paradigm shift in the rail industry. With no oil in the system, the compressed air output is clean and free of oil. The Knorr-Bremse oil-free piston compressor **PistonSupply Eco** (VV-T 2.0) offers an outstanding combination of high performance, low vibration and noise levels, combined with worldwide field experience. Continuous technical improvement has now led to the next generation oil-free piston compressors.



Customer benefits

- Service-proven product with more than 40,000 units sold
- Oil-free air is environmentally friendly and causes no downstream contamination
- Cold starts without preheating, down to -50 °C
- Specially optimized design to minimize noise and vibrations
- No oil exchange, no disposal of used oil, no contaminated condensate to collect



KNORR-BREMSE



Key features

- Designed for railroad applications
- Continuously improved product based on long-term worldwide experience
- Less complex system with fewer interfaces than conventional compressor systems
- Robust design for underfloor mounting conditions as well as for standing installation, roof-mounted or interior



PistonSupply Eco in detail

Inter/After cooler

- Combined inter/after cooler
- Compressed air outlet

Fan with viscous coupling*

Air filter

Metal bellow coupling

Crankcase

- 2x low pressure cylinders
- 1x high pressure cylinder
- Pressure, suction & safety valve
- Integrated crankshaft

AC-motor

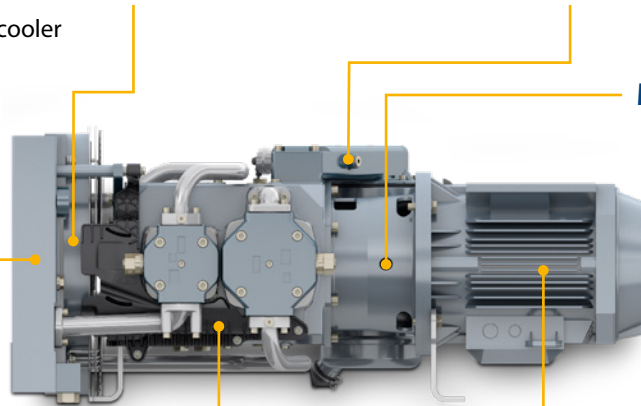

We offer a wide variety of compressors for multiple applications

- High-speed trains
- Regional & commuter trains
- Metros
- Light rail vehicles
- Monorails
- Locomotives
- Special vehicles

Type	Air Delivery 50 / 60 Hz
VV40-T	255 / 315 l/min
VV80-T	435 / 520 l/min
VV90-T	530 / 625 l/min
VV120-T	815 / 980 l/min
VV180-T	1450 / 1750 l/min
VV270-T	2000 / 2400 l/min
VV450-T	3100 l/min
VV1000-T	2750 / 5250 l/min

*except VV40-T, VV80-T and VV90-T

Knorr-Bremse Systeme für Schienenfahrzeuge GmbH

Moosacher Straße 80
80809 Munich
Germany
Phone: +49 89 3547-0
Fax: +49 89 3547-2767
rail.knorr-bremse.com

