



EDT®101 PNEUMATIC DERAILMENT DETECTOR

EDT®101 activates an automatic emergency stop in case of derailment. Comprising an emergency brake valve, a mounted spring-mass valve and an indicator device, EDT®101 registers any increase in vertical acceleration and automatically releases the emergency brake by venting the main brake pipe. Then the EDT®101 returns to its normal operation position independently and a red pin on the indicator device shows which unit has triggered. The indicator pin easily can be reset manually. By a stopcock in the bracket of the device the detector can be deactivated manually at any time. This highly secure system can be retrofitted easily to existing wagons and has demonstrated its value over years – around the world.



Customer benefits

- Reduces damage caused by derailment
- Increases safety for people, goods and the environment
- Immediate train brake activation when a derailed axle is recognized
- Easily retrofitted to existing wagons
- Highly reliable
- Independent system
- UIC-homologated



Applications

- Freight cars
- Transportation of hazardous goods



KNORR-BREMSE



Installation

- Two derailment detectors per vehicle
- Mounted at a strategic position on the chassis of the wagon
- Easily connected to the main brake pipe (using a branch flange)
- Mounted on a special bracket with integrated stopcock

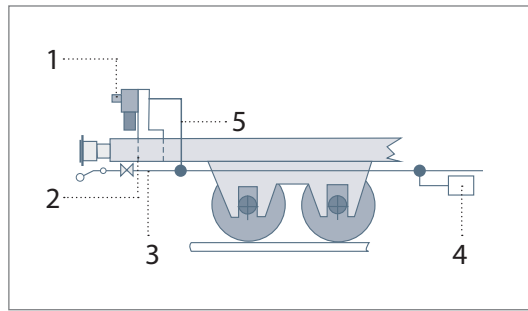

- 1 Derailment detector and bracket with integrated stopcock
- 2 Buffer beam
- 3 Brake pipe
- 4 Distributor valve
- 5 Connecting pipe



Technical data

- Secure triggering vertical acceleration > 11.5 g (0 - 100 Hz)
- Secure non-trigger vertical acceleration < 6.5 g (0 - 100 Hz)
- Medium treated air (DIN/ISO 8573-1)
- Service pressure 5.0 bar
- Maximum pressure 8.0 bar
- Connecting pipe min. Ø 19 mm
- Venting pipe min. Ø 19 mm
- Operational temperature -40 °C to +70 °C

Functional diagram

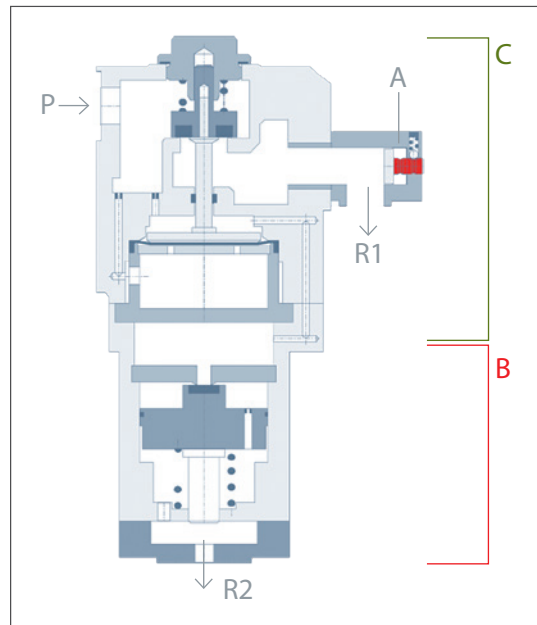

- A Indicator device
- B Spring-mass valve
- C Emergency brake valve
- P Compressed air connection, main air pipe
- R1 Air outlet, main air pipe
- R2 Air outlet, control air

Knorr-Bremse Systeme für Schienenfahrzeuge GmbH

Moosacher Straße 80
 80809 Munich
 Germany
 Phone: +49 89 3547-0
 Fax: +49 89 3547-2767
 rail.knorr-bremse.com



KNORR-BREMSE

NEW YORK AIR BRAKE

IFE

MERAK

MICROELETTRICA

SELECTRON

EVAC

ZELISKO

RAILSERVICES