

SYSTEM INTEGRATION IN CONTAINER OR FRAME

Customer benefits from project-specific integration of braking equipment: Knorr-Bremse has both the competence and the capacity to design and deliver ready-to-install brake control modules (BCM) that meet customers' precise requirements. The car-specific, maintenance-friendly containers or frames optionally contain all the necessary air supply equipment as well.

Customer benefits

- Pre-assembled brake control in a frame with pre-tested components
- Optionally contains air-supply components
- Optionally contains electronics unit
- Perfectly matched to project requirements
- Highly integrated design with plug-and-play installation into car
- Reduced complexity in engineering, logistics, assembly and testing

- Maintenance-friendly service concepts reduce operators' TCO
- Good protection against environmental influences

Applications

- High-speed trains
- Locomotives
- Metros
- Passenger coaches
- Regional & commuter trains



KNORR-BREMSE

Key features

Design

- Compact design in defined installation space according to valid norms and experience from the operating countries (e.g. environmental conditions)
- Wiring according to valid norms for shielding, protection, earth & fire safety

Testing

- Comprehensive pneumatic & electric tests before shipping → ready to install

Logistics and Commissioning

- Management from only one supplier, reduced commissioning effort
- Reduced manufacturing lead time and logistic effort compared to non-integrated strategy

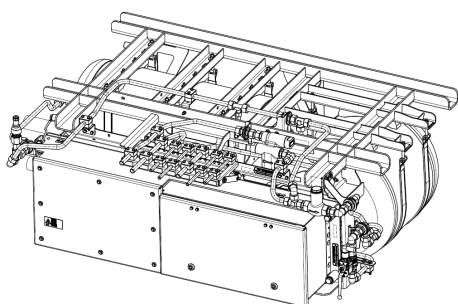

Selected reference projects

Metro

- Alstom – Amsterdam metro
- Bombardier – Singapore MRT
- CSR – New Delhi DLF metro
- Changchun Railway – Mecca metro project

High-speed trains

- CRRC – CRH5A (see cover picture)
- Siemens – VELARO Eurostar

Assembly and Integration into the Train

- Plug & play with pneumatic & electric interfaces according to customer requirements
- Less design effort for the vehicle builder, supply of 3D-step file if desired
- Faster integration → shorter production process, less warehouse space needed, less testing effort on customer side

Maintenance and Overhaul

- Central terminal block for interfaces, easy access to all control elements and test points
- Overhaul instructions are created by Knorr-Bremse on module level if desired
- Quick replacement of complete frame for overhaul (can be sent back to Knorr-Bremse for rework)
- Protection against environmental influences (temperature, dust, vibration, shock) leads to longer life cycles and reduced LCCs
- Availability of all components over the contractual lifetime

Regional & commuter

- Siemens – DESIRO RUS
- CAF – Auckland EMU

Locomotives

- Siemens – Vectron
- Alstom – Madhepura
- Bombardier – GFB
- Dalian – HXD3
- ZELC – HXD1

Knorr-Bremse Systeme für Schienenfahrzeuge GmbH

Moosacher Straße 80
80809 Munich
Germany
Phone: +49 89 3547-0
Fax: +49 89 3547-2767
rail.knorr-bremse.com



 **KNORR-BREMSE**

 **NEW YORK AIR BRAKE**

 **IFE**

 **MERAK**

 **MICROELETTRICA**

 **KIEPE ELECTRIC**

 **SELECTRON**

 **ZELISKO**

 **RAILSERVICES**