



TRACTION CONVERTER KIEPE TU 600.01

FOR MODERNISATION OF A CLASS 455 EMU, UK

Compact power for regional and commuter trains

- Axle-selective drive
- Recuperable electrodynamic brake
- Integrated brake resistor
- Adaptation to existing vehicle interfaces
- SIL2 drive control with integrated wheel slide protection and anti-slip
- Reliable compatibility with Network Rail's strict requirements for interference current
- Fast and easy maintenance due to modular design
- Compatible with RIA 12



KIEPE ELECTRIC

Technical Data

Electrical data

Input	
Nominal voltage	750 V DC (3 rd rail)
Operating range	400 – 900 V DC

Motor output	
Nominal voltage	3AC 400 V
Nominal power (S1)	2x 250 kW
Nominal current (S1)	443 A
Max. frequency	95 Hz

Braking resistor output	
Nominal voltage	900 V DC
Peak power	650 kW

Mechanical data

Dimensions (length x width x height) (with brake resistor, without terminal box, clamping shoes)	2310 mm x 2000 mm x 600 mm
Weight	approx. 1900 kg
Place of installation	Underfloor
Cooling	Forced air cooling
Degree of protection	IP 54
Temperature range	-25 °C to + 45 °C

Änderungen vorbehalten

Block Diagram

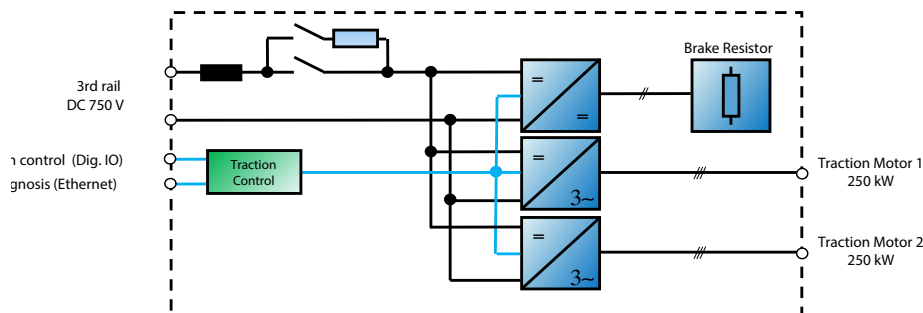
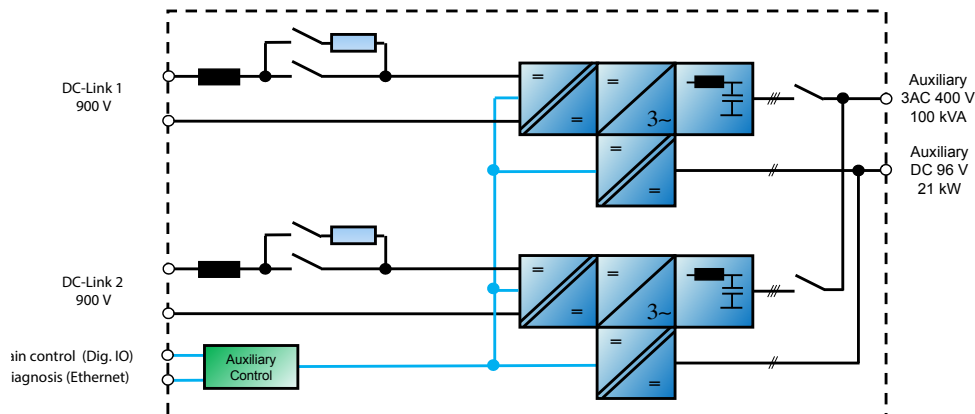

Kiepe Electric GmbH

Kiepe-Platz 1
 40599 Düsseldorf
 Tel: +49 211 7497-0
 Fax: +49 211 7497-300
 info@kiepe.knorr-bremse.com
 www.kiepe.knorr-bremse.com

