



# LED SIGNAL EU

## APPLICATIONS

Trackside signaling



**ZELISKO**

# Zelisko LED Signal EU combines high visibility with low life-cycle costs

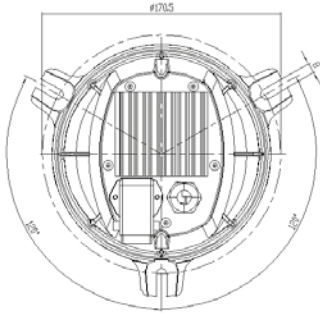

Dimensions 100 mm signal (without visor)

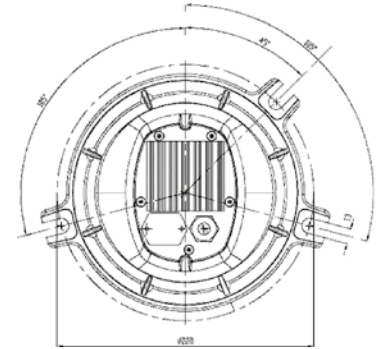
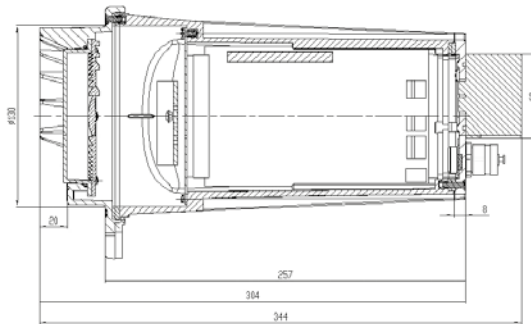

Dimensions 160 mm signal (without visor)

around 80,000 LED signal EU systems installed worldwide illustrate that the replacement of bulb with LED signals, retaining safety level 4, is the way forward for signaling.

## Features

- According to CENELEC EN 50 129 safety integrity level SIL4
- Complete Assessment Report by TÜV
- 7 / 4 high-power LED
- No preventive maintenance required – high availability
- High optical efficiency
- Power curve programmable (resistive characteristic)
- AC & DC variants
- Reproduction of light bulb behavior
- Independently adjustable light intensity for day or night
- Compatible with commonly used interlocking systems
- Current-voltage monitoring of LED
- Serial connection and blinking operation
- Pre-warning of failure of one LED depending on variants
- Safe shutdown in case of fault
- Protection class IP54 (IP65 on request)
- Connection via plug or fixed cable

## Variants

U <sub>nenn</sub>	P <sub>nenn</sub>	FUNCTION	SAFETY	PRE-WARNING	RED	YELLOW	GREEN	WHITE	BLUE	PURPLE
12VAC	35W	day/night	SIL4	×	×	×	×	×	×	
12VAC	50W	day/night	SIL4	×	×	×	×	×	×	
12VDC (pulsating)	20W	day/night	SIL4	×	×	×	×	×	×	
12VAC	20W	day/night	SIL4	×	×	×	×	×	×	×
20-40VDC	20W	day/night	SIL4		×	×	×	×	×	×
24VDC	20W	2 filament	SIL4		×					
24VDC	12W		-			×		×		
6-30VDC	3W		-		×	×	×			

Other variants are available



## Developed in Austria – Delivered worldwide!

After years of gaining experience with the delivery of LED signals in Austria, Zelisko started to look beyond the borders and is extending the market by participating in international projects. This page shows the most important references for Zelisko's LED signal technology. Beside safety level class SIL 4, best optical performance and compatibility with the most commonly used interlocking types are the key for success.





Austria



Algeria



Slovakia



Italy

**Wherever top quality is crucial for competitiveness, Zelisko offers cutting-edge technology!**

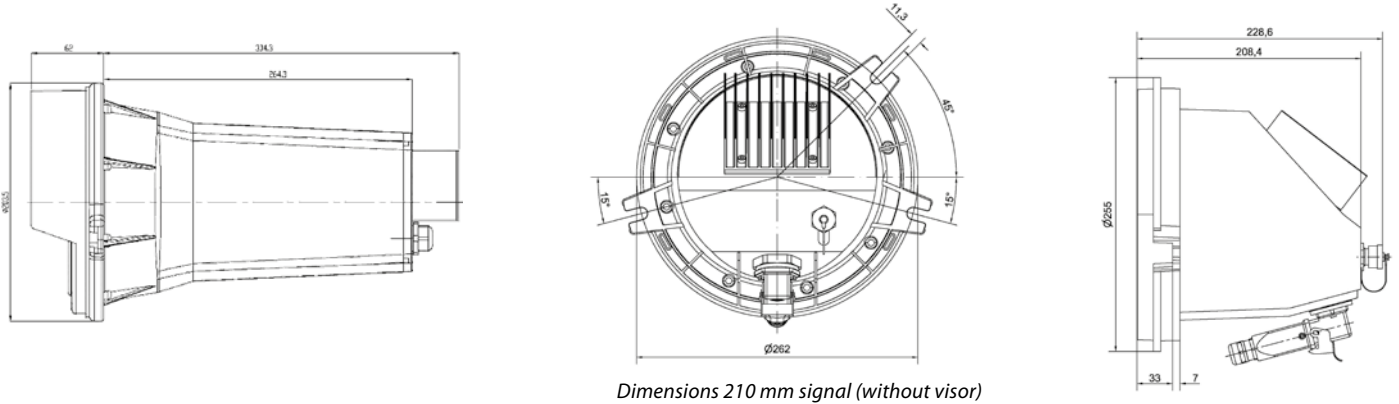

Dimensions 210 mm signal (without visor)



LED signal EU 100 mm

LED signal EU 100 new design

LED signal EU 140 mm

LED signal EU 160 mm

LED signal EU 210 mm

**Technical Data**



indicator

Luminous intensity			red / amber / green / white		blue		purple	
			min.	max.	min.	max.	min.	max.
Luminous intensity 210 mm signal	typ. [cd]	day	1000	3000	1000	3000		
		night	350	1000	350	1500		
Luminous intensity 160 mm signal	typ. [cd]	day	1000	3000	1000	3000	700	2100
		night	350	1500	350	1500	250	700
Luminous intensity 100 mm signal	typ. [cd]	day	600	1800	600	1800		
		night	200	600	200	600		

Electrical parameters for 12 V AC/20 W standard version		Value			Unit
		min.	typ.	max.	
Voltage daytime operation	U <sub>day</sub>	10.8	12	13.2	V <sub>AC rms</sub>
Current daytime operation	I <sub>day</sub>	1.1		1.9	A <sub>AC rms</sub>
El. power daytime operation	P <sub>day</sub>		20		W <sub>eff.</sub>
Voltage nighttime operation	U <sub>night</sub>	7.2	8	9.0	V <sub>AC rms</sub>
Current nighttime operation	I <sub>night</sub>	0.9		1.4	A <sub>AC rms</sub>
Frequency	f	47	50	53	Hz
Switch-off current	I <sub>off</sub>			850	mA <sub>AC rms</sub>
Switch-on	U <sub>on</sub>	-	7	7.2	V <sub>AC rms</sub>
Switch-on delay	t <sub>on</sub>	-	90	150	ms
Undervoltage switch-off	U <sub>off</sub>	5		6.9	V <sub>AC rms</sub>
Flashing frequency (50/50)	f <sub>blink</sub>	-	1	1.5	Hz

**Light distribution**

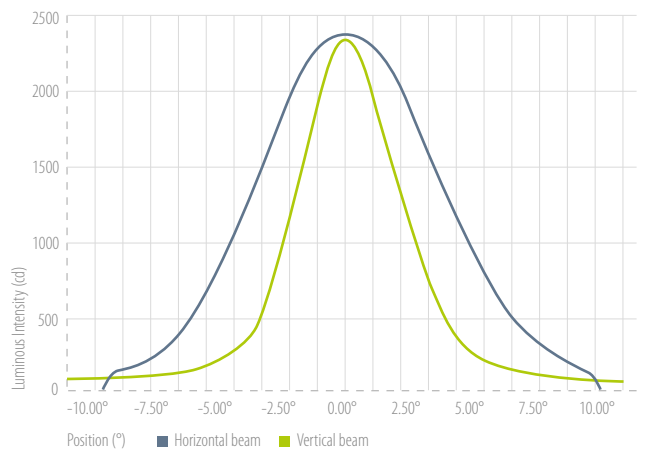

Errors and technical modifications are excepted.

**Dr. techn. Josef Zelisko,  
Fabrik für Elektrotechnik  
und Maschinenbau  
Gesellschaft m.b.H.**

Beethovengasse 43-45

2340 Mödling

Austria

Phone: +43 2236 409-2229

Fax: +43 2236 409-2279

[www.zelisko.com](http://www.zelisko.com)

[www.knorr-bremse.com](http://www.knorr-bremse.com)



---

 **KNORR-BREMSE**

---

 **NEW YORK AIR BRAKE**

---

 **IFE**

---

 **MERAK**

---

 **MICROELETTRICA**

---

 **SELECTRON**

---

 **KIEPE ELECTRIC**

---

 **EVAC**

---

 **ZELISKO**

---

 **RAILSERVICES**

---